

LOTUS DAN 2008

16. oktober 2008, Sora pri Medvodah

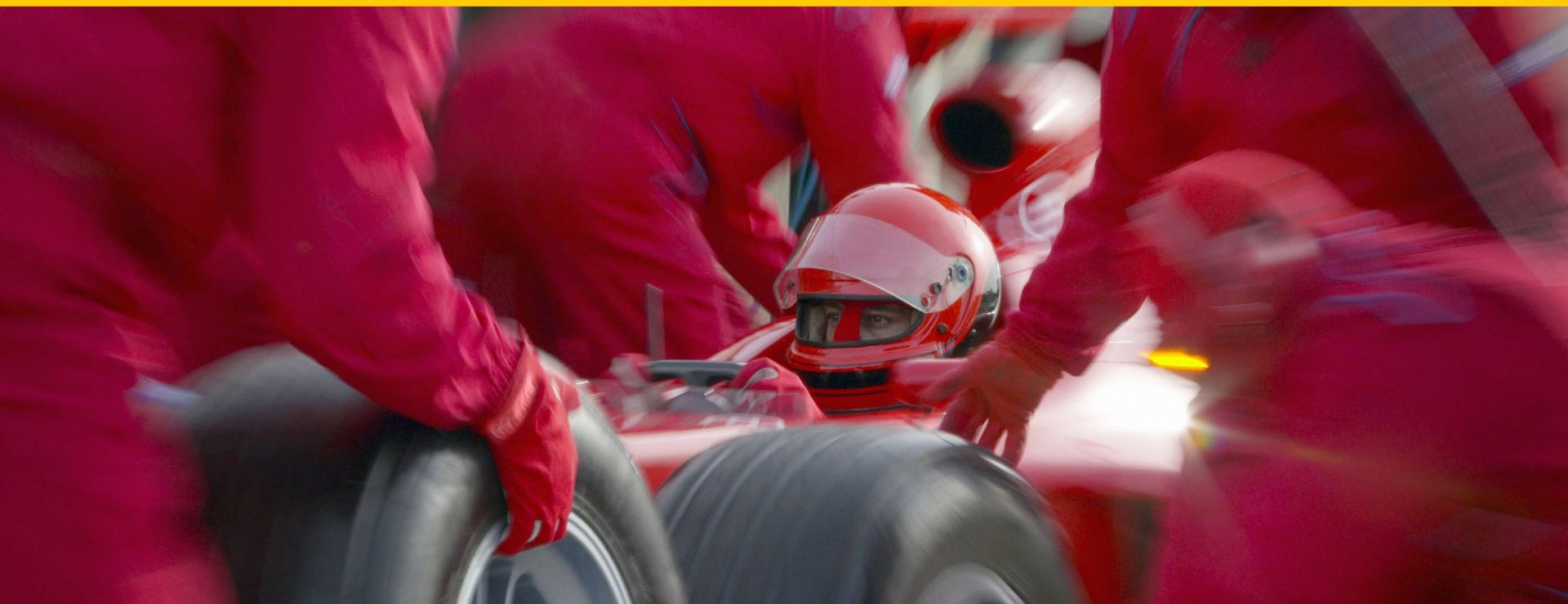

Kako z Lotus programsko opremo urediti SDM?

Janko Štefančič, GENIS

Kdo?

- Tehnični direktor e-Poslovanja
- Certificiran strokovnjak za Lotus
- Predstavnik nove generacije zaposlenih
- Aktiven član/člen t.i. družbenega omreženja



<http://www.genis.si/janko/janko.nsf>

janko.stefancic@genis.si

Agenda



- Poslanstvo
- Klasična opredelitev delovnega mesta
- Nova generacija zaposlenih
- Splet 2.0 → Podjetje 2.0 → Družba 2.0 ?
- Sodobno delovno mesto
- **LOTUS!** Zakaj?
- Izzivi



POSLANSTVO

- “Poslovnim partnerjem omogočamo **uvedbo NOVIH poslovnih modelov** v INTEGRACIJI STORITEV z NAJBOLJŠO PRAKSO v:
 - organizaciji
 - procesih in
 - uporabi informacijske tehnologije.”

VREDNOTE

- **Profesionalnost**
- **Sodelovanje**
- **Inovativnost**
- **Znanje**
- **Povezovanje**
- **Zaupanje**
- **Druženje**



10+ let dobre prakse



član skupine Sandoz



Mladinska knjiga
ZALOŽBA

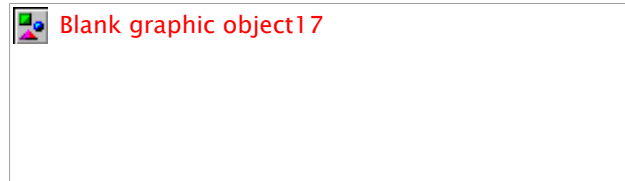

B/S/H/



Zaposleni danes

- Kdo, S čim, Kje //
Kaj, Kako //
Zakaj, Kdaj
- Zaposleni so “orodje”
- Izvajajo naloge v okviru zahtev
 - nivo samoiniciative
- Formalna organizacija / hierarhija



Preobremenjenost

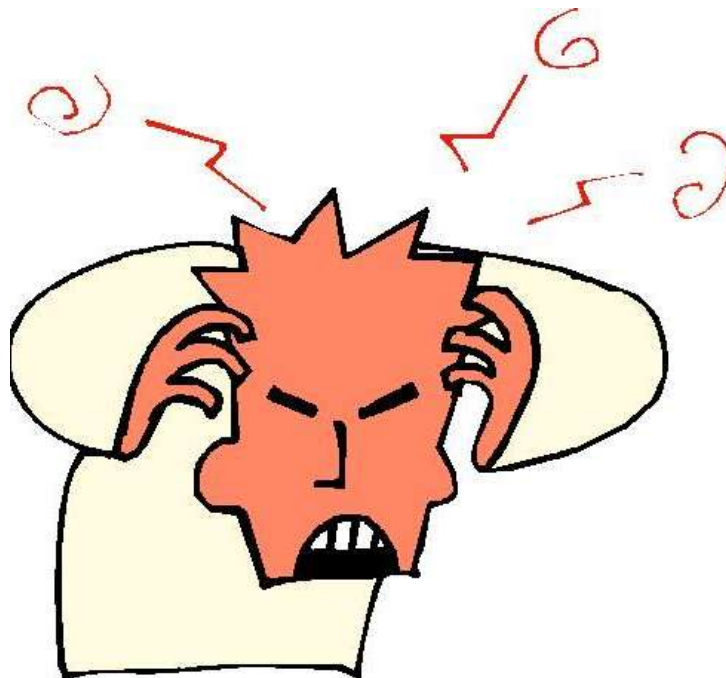

- do 70% časa porabimo za iskanje **PRAVIH** informacij

Komunikacija



- Osnovna komunikacija
- Takojšnje sodelovanje
- Enovita komunikacija
- **Integrirane funkcionalnosti sodelovanja**

HOW TO USE WEB 2.0 IN THE ENTERPRISE



PART 1:
COMMUNICATE WITH YOUR EMPLOYEES

[http://
geekandpoke.typepad.com/](http://geekandpoke.typepad.com/)

HOW TO USE WEB 2.0 IN THE ENTERPRISE

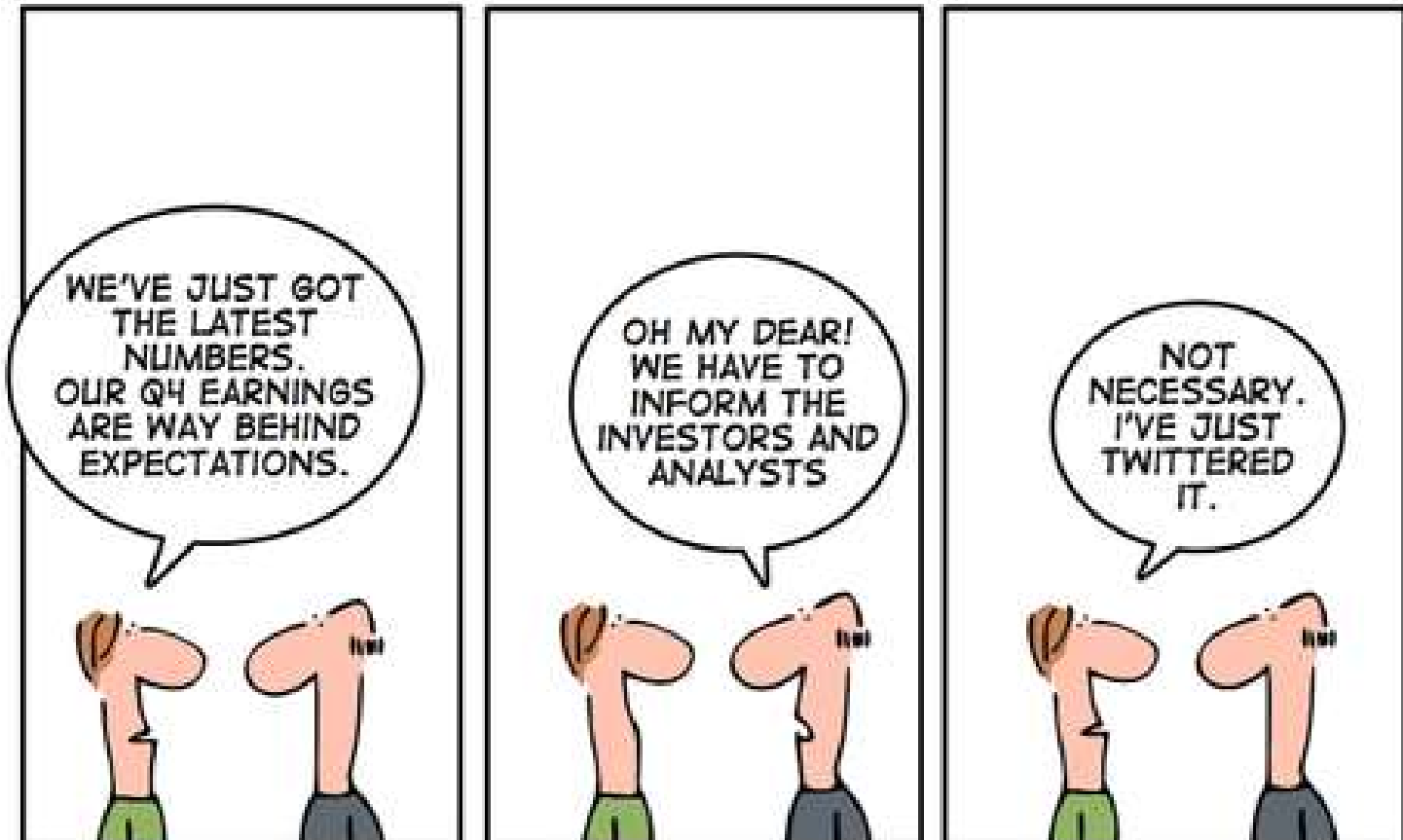

PART 2: COMMUNICATE WITH YOUR INVESTORS

<http://geekandpoke.typepad.com/>



Kaj so družbene vsebine

- Upravljanje z znanjem?

VEČ!

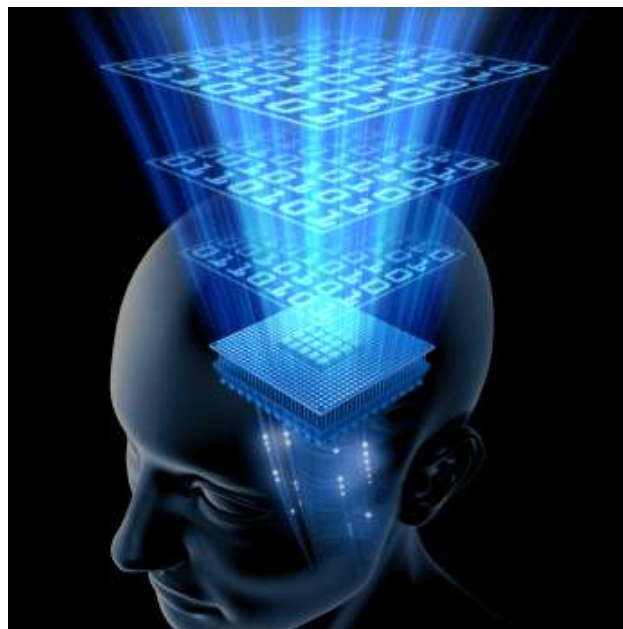

VEČ!

- Ljudje prostovoljno delijo ideje / informacije / znanje

Splet 2.0

- Blog
- Wiki
- Twitter
- Družbeno omreženje (Facebook, LinkedIn)
- Skupinski zaznamki (Digg, del.ico.us)

- Druženje, izmenjava izkušenj, znanj, ...

=

dolgčas / zapravljanje časa ali ?

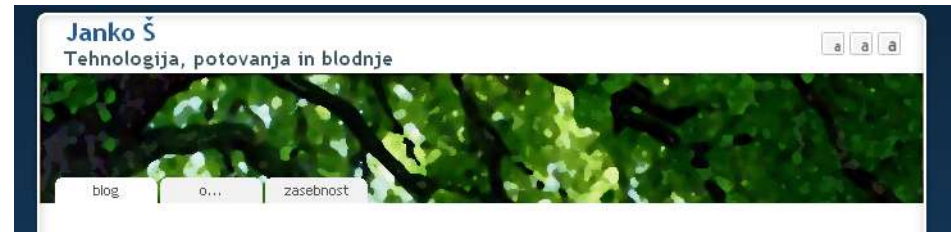

The Twitter logo, consisting of the word 'twitter' in a light blue, lowercase, sans-serif font with a white outline.

Podjetje 2.0

- “SaaS”
- “Cloud computing”
- Google
- Družbeno omreženje?
- Zaposleni so vir
 - znanja
 - inovacij

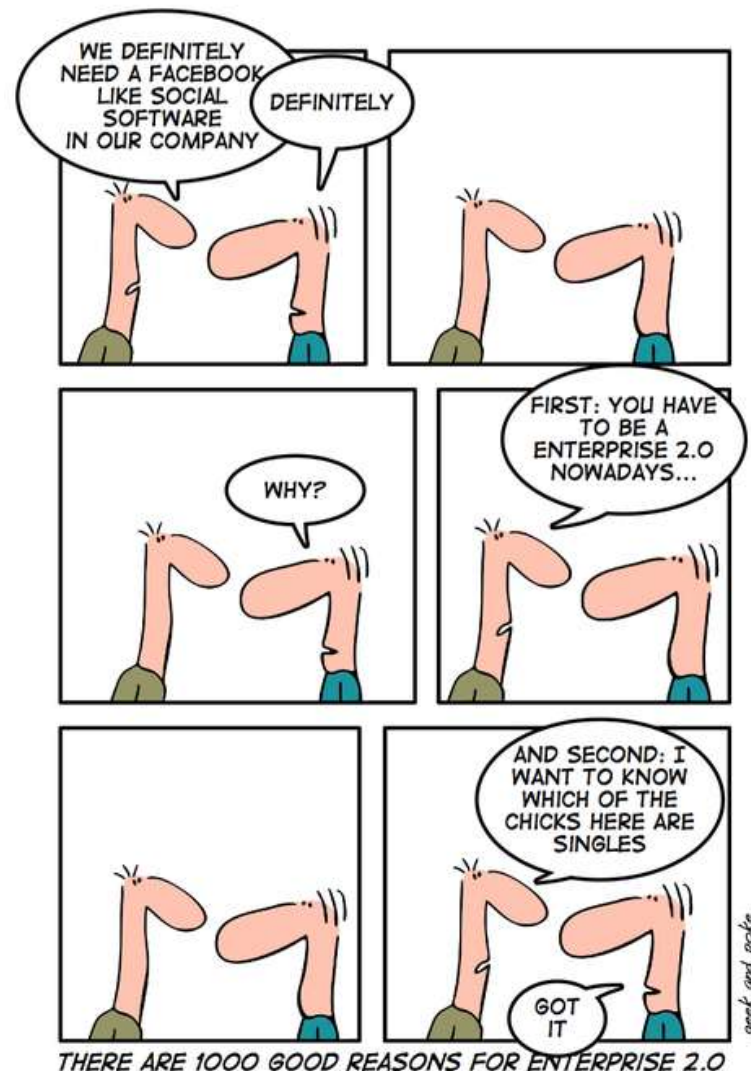

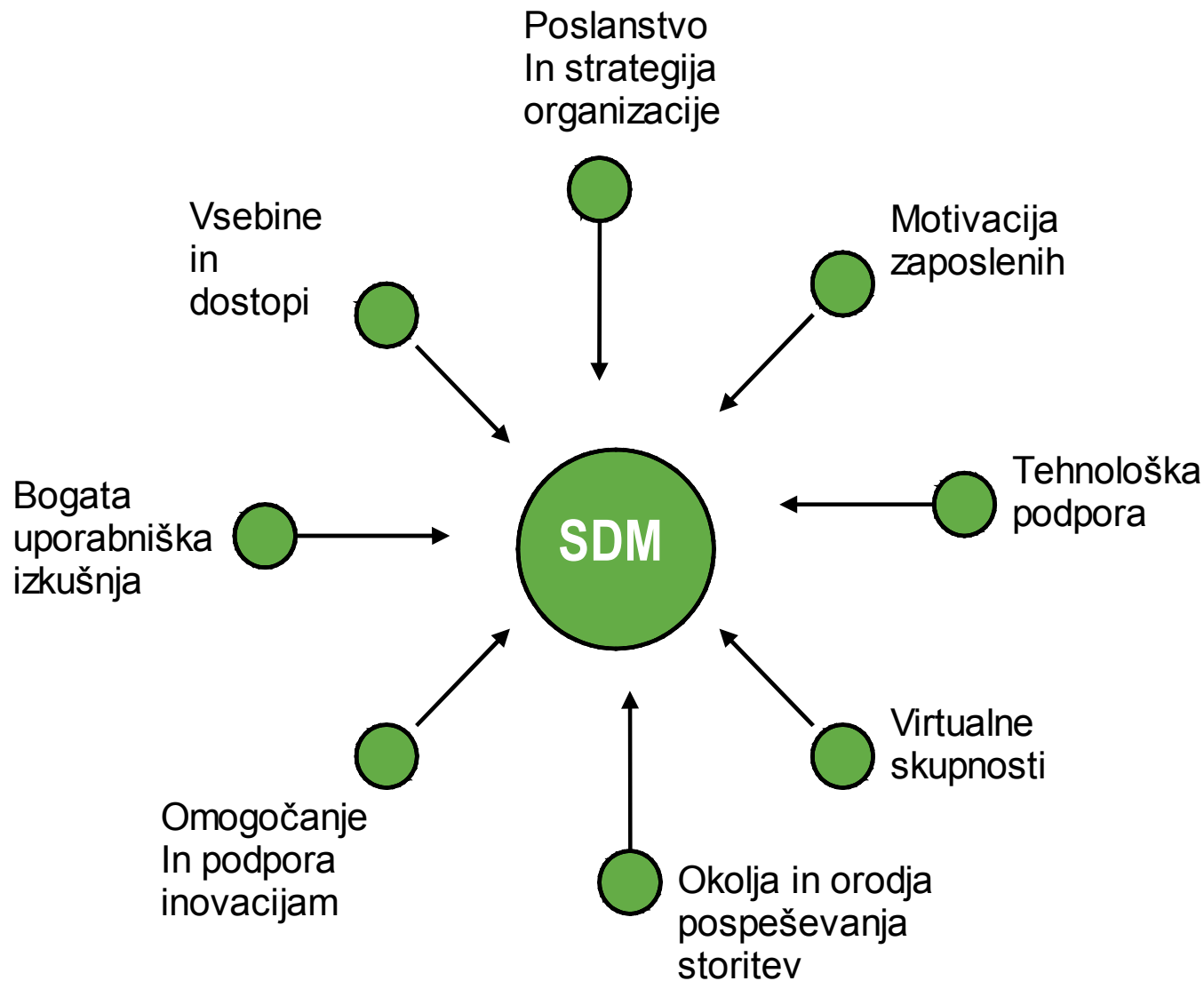
Sodobno delovno
mesto



Lotus Connections

IBM Lotus Connections Home Page - Mozilla Firefox
 http://dom85.renovations.com/homepage/web/getuserpref

Menu Dogear Search

Lotus, Connections **Home** Profiles Communities Blogs Dogear Activities Jasmine Haj | Help | Logout

Home Search All

Profiles

My Colleagues

- Frank Adams**
No Activities updates | 2 Blogs updates | 10 Dogear updates
- Heather Reeds**
No Activities updates | 1 Blogs updates | 10 Dogear updates

Viewing 1-2 of 2 colleagues

Search By: Name

Blogs

Latest Blog Entries

- Visiting Boston**
Heather Reeds | 15 May | Details | 5 stars | 2 comments
- Cool new social software tools**
Frank Adams | 15 May | Details | 2 stars | 1 comment
- Issues with lighting installation kit**
Frank Adams | 14 May | Details | 5 stars | 2 comments

Viewing 1-3 of 11 blog entries

Activities

My Activities

May 2008						
S	M	T	W	T	F	S
27	28	29	30	1	2	3
4	5	6	7	8	9	10
11	12	13	14	15	16	17
18	19	20	21	22	23	24
25	26	27	28	29	30	31
1	2	3	4	5	6	7

2007 2008 2009

Friday, May 23, 2008

- 1 new responses to your posts
- View new entries in your high priority activities
- My Activities

Communities

My Communities

- Federal Programs Community**
Jasmine Haj | Today 11:26 AM
Feeds | Bookmarks | Forums
- Worldwide Sales Community**
Jasmine Haj | Today 11:26 AM
Feeds | Bookmarks | Forums
- Green Hands Community**
Jasmine Haj | Today 10:59 AM
Feeds | Bookmarks | Forums

Viewing 1-3 of 5 communities

Dogear

Recent Bookmarks

- Synch.rono.us**
Ling Shin | 15 May | Details
- IBM United States**
Ling Shin | 15 May | Details
- My Activities**
Ling Shin | 15 May | Details

Viewing 1-3 of 6542 bookmarks

IBM Lotus Connections

- Home
- Demo

Help

- Help
- IBM Lotus Support Forums

Tools

- How to Bookmark

About

- About
- IBM Lotus Connections on ibm.com
- Submit Feedback

Lotus Notes 8

The screenshot displays the Lotus Notes 8 interface. At the top, the menu bar includes File, Edit, View, Create, Actions, Tools, and Window. Below the menu is a toolbar with icons for New, Reply, Reply to All, Forward, and other actions. The left sidebar shows the 'Janko Stefančič - Mail' workspace with folders like Inbox (12), Drafts, Sent, Follow Up, All Documents, Junk, Trash, Chat History, Views, Folders, Archive, Tools, and Other Mail. The main pane shows an email list with columns for Sender, Subject, Date, and Size. The selected email is from Damjan Florjančič with the subject 'DOGODEK: "Lotus dan 2008", 16. oktober 2008, Hiša kulinarike Jezeršek, Sora pri Medvodah'. Below the email list, the content of the selected email is displayed, including a forwarded message and a large promotional banner for 'LOTUS DAN 2008'. The banner features a racing helmet and the text 'MEDESEBOJNO SODELOVANJE IN INOVACIJE DAJEJO ZAGON. ZAŽENITE SVOJE NAPRAVE.' and 'LOTUS DAN 2008 16. oktober 2008, Hiša kulinarike Jezeršek, Sora pri Medvodah'. The right sidebar contains 'Sametime Contacts' with a list of contacts, 'My Widgets' with icons for 'Proje.d' and 'Genis splet...', 'Feeds' with '2tur.com (29)' and 'Genis d.o.o (3)', and a calendar for September 2008. The bottom status bar shows 'TwitNotes v. 1.0.5' and 'Online'.

Sender	Subject	Date	Size
Mihael Škarabot	Image to Buffered Image	26.11.2007 13:29	10K
Darko Jagarinc	Zaključevanje zahtev	22.07.2008 08:15	2K
Marko Čadež	Pregled realiziranih ur	01.08.2008 13:05	5K
Janko Stefančič	aljz.mali@cetrtrapot.si	04.08.2008 16:27	8K
Danijel Regojevič	Predlog za zaključitev [Zahteva 13359] izdelava ARHIV-a za Zahteve	02.09.2008 08:31	1K
Ana Štefe	IMEP - spremembe na prototipu	25.09.2008 09:16	41K
Gerry McManus	RE: AGA	25.09.2008 13:13	58K
Jure Tomc	Re: Poročanje na zahtevo - predlog za dopolnitev	26.09.2008 11:13	9K
Damjan Florjančič	DOGODEK: "Lotus dan 2008", 16. oktober 2008, Hiša kulinarike Jezeršek, Sora pri Medvodah	29.09.2008 13:04	93K
podpora	Operations Manager Service Unavailable Alert on GENIS/CASTOR	29.09.2008 15:09	3K
Gerry McManus	RE: AGA	29.09.2008 15:21	58K
Danijel Regojevič	ISKRAEMECO - poročilo testiranja prehoda iz Klienta LN 5 na LN 8.0.2	29.09.2008 15:30	43K
Mitja Zakotnik	Naslovni banner na www.genis.si	29.09.2008 15:35	1K
LotusUserGroup.org	Virtual User Group Meeting: Integrate SharePoint with Lotus Notes: Strategic Coexistence	29.09.2008 16:03	12K
LotusUserGroup.org	Sys Admin Tips Newsletter - Choosing Domino as Your LDAP Solution	29.09.2008 18:31	30K
LotusUserGroup.org	Developer Tips Newsletter - Back to School	29.09.2008 22:09	34K

DOGODEK: "Lotus dan 2008", 16. oktober 2008, Hiša kulinarike Jezeršek, Sora pri Medvodah
 Damjan Florjančič to: 29.09.2008 13:04
 Show Details

History: This message has been forwarded.

MEDESEBOJNO SODELOVANJE IN INOVACIJE DAJEJO ZAGON.
 ZAŽENITE SVOJE NAPRAVE.

LOTUS DAN 2008
 16. oktober 2008, Hiša kulinarike Jezeršek, Sora pri Medvodah

Pridružite se nam na IBM Lotus dnevu 2008 in se prepričajte, kako lahko Lotus-ova inovativna orodja za medsebojno sodelovanje pomagajo optimizirati način vašega poslovanja.

RESNIČNI PRIMERI IZ POSLOVNEGA SVETA. KI OMOGOČAJO VPOGLED V OBSTOJEČE NAČINE

Lotus Quickr

The screenshot displays the Lotus Quickr web interface. At the top, there are navigation tabs for "Lotus Quickr", "Places", and "Files". The user's name "Heather Reeds" and links for "Help" and "Logout" are visible in the top right. Below the navigation, there are tabs for "My Files" and "Find People", along with a search bar labeled "Search All".

The main content area is titled "Files for Heather Reeds" and includes a link to "Add Heather Reeds to your connectors". Below this, there is a list of files with the following details:

File Name	Downloads	More
Energy Savings Data for the Go Green Program at Renovations Added Jan 20 at 11:49AM	2 Downloads	More
Go Green Program - Reduction Notes Added Jan 20 at 11:21AM	0 Downloads	More
Building a Culture of Sustainability at Your Company.doc Added Jan 20 at 9:54AM An overview of how to establish good habits and attitudes towards sustainability at your company. From the 2007 Enterprise Sustainability Conference. Recommend Delete Edit Replace	0 Downloads	Hide
Green Economics Cost Savings.xls Added Jan 20 at 9:08AM	4 Downloads	More
Renovations Go Green Program Demo Added Jan 19 at 5:42PM	2 Downloads	More
Project Green Hands Environmental Research Study Added Jan 19 at 4:12PM	5 Downloads	More

On the left side of the interface, there is a sidebar with the following sections:

- Upload a File**: A green button to initiate file uploads.
- Most Recent**: A green button to view recently added files.
- Most Downloaded**: A blue button to view files with the highest download counts.
- Title**: A text input field for searching files by title.
- Time**: A dropdown menu with options for "all time", "today", "last week", "last month", and "last year".
- Upload to Library**: A section with the text "Drag Files and folders from your computer to upload" and a graphic of a document being dragged into a folder.

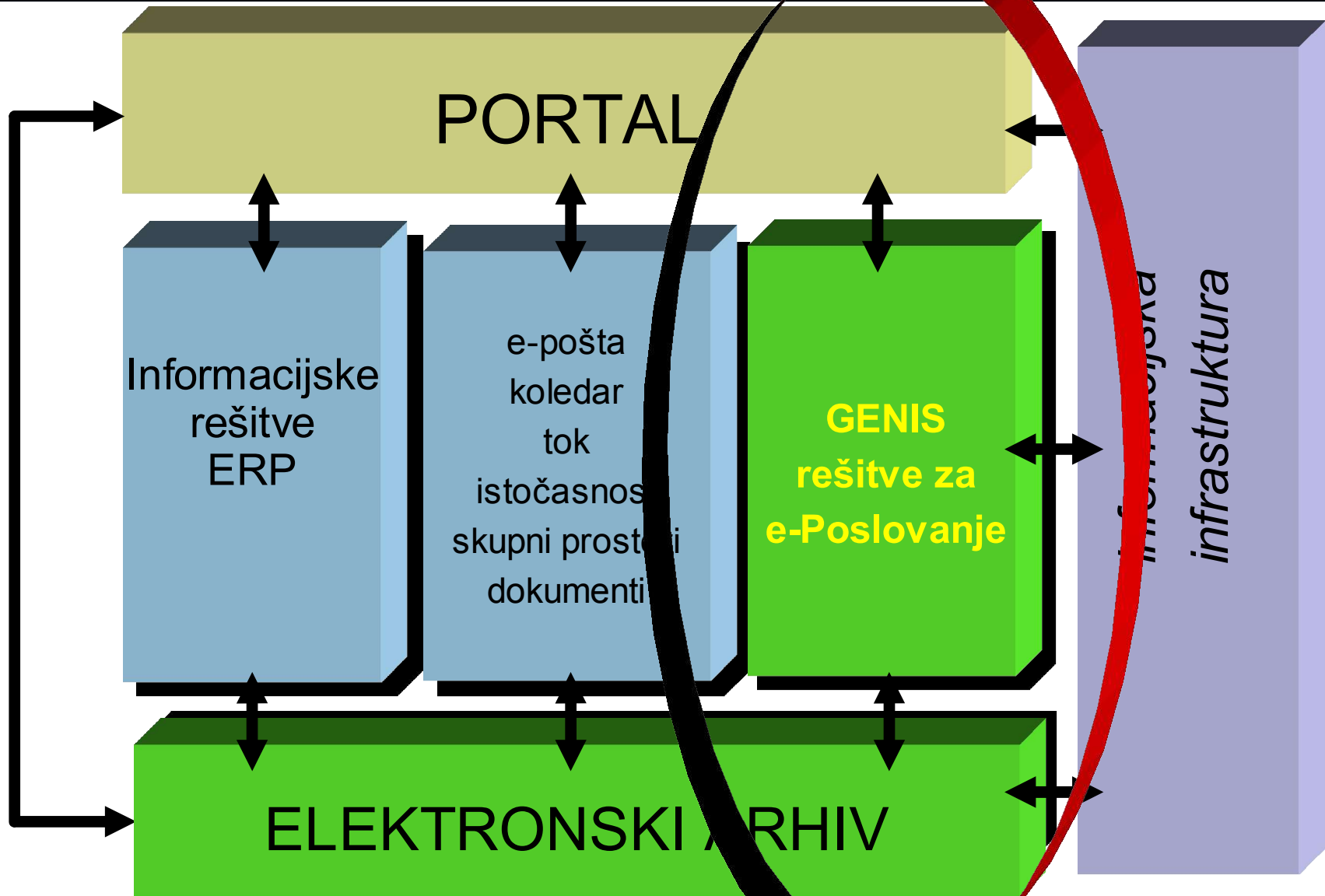

Celovita podpora prodajno-projektnim procesom

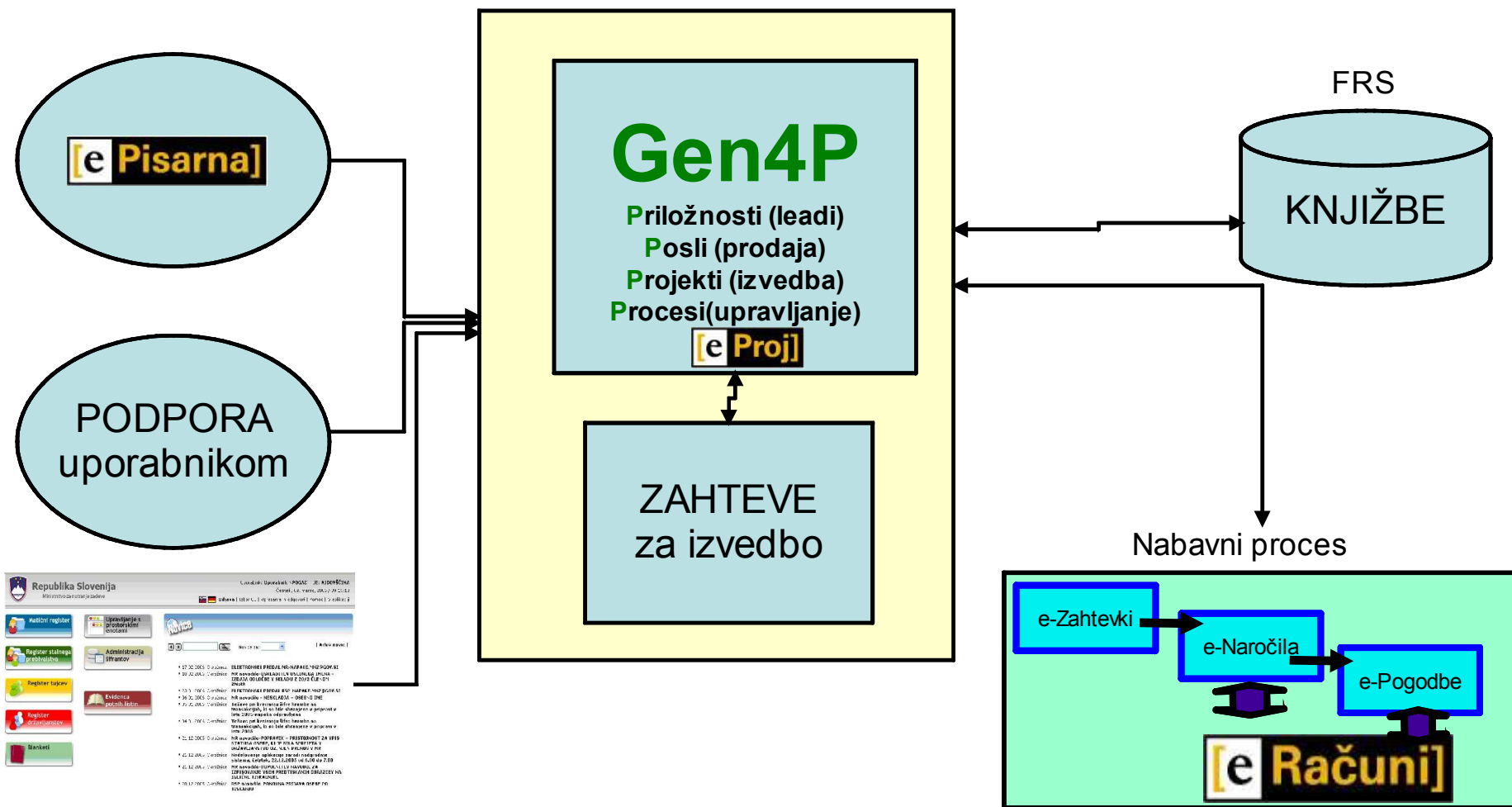

Izzivi

- Tehnologija omogoča, ni pa ključni nosilec zmogljivosti delovnega mesta
- Izkoristiti skriti potencial v mladih / zaposlenih
- “premakniti” organizacijo
- nič ni nerešljivo

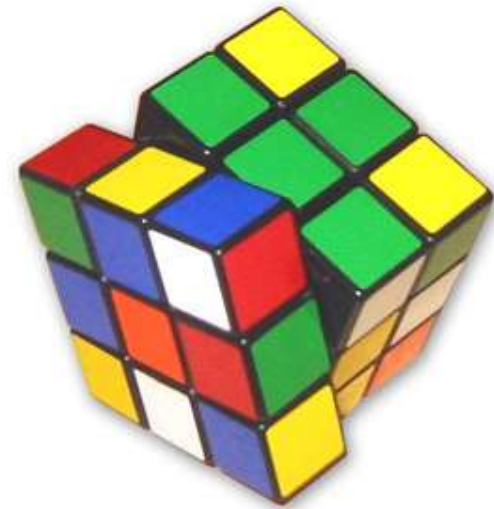

Hvala za Vašo pozornost



Janko Štefančič

<http://www.genis.si/janko/janko.nsf>

janko.stefancic@genis.si