

Tivoli Storage Manager™ and ADINT/TSM for mySAP™ with MaxDB™



Content:

Additional information sources	p. 2
Summary	p. 3
MaxDB™ Backup/Restore with ADINT/TSM	p. 3
Complete mySAP™ Backup/Restore	p. 5
Ancillary Functions – Cloning and Archiving	p. 6
ADINT/TSM Benefits and Features	p. 8

Positioning ADINT/TSM for mySAP™ with MaxDB™

For more information on ADINT/TSM, Tivoli Storage Manager or CommonStore please

contact your IBM Sales Representative or

check www.ibm.com/de/entwicklung/esd/ for up-to-date information on ADINT/TSM

or send your inquiry via email to backint@de.ibm.com.

For more information on MaxDB™ pls check
www.mysql.com/products/maxdb/

Trademark Statement

IBM, Tivoli and Tivoli Storage Manager, and CommonStore are trademarks of IBM Corp. in the US and other countries.

The following are trademarks or registered trademarks of other companies:

MaxDB is a trademark of mySQL AB.

mySAP, Netweaver and R/3, Knowledge Provider and liveCache are trademarks of SAP AG.

UNIX is a registered trademark of The Open Group in the US and other countries.

Linux is a registered trademark of Linus Torvalds.

Microsoft, Windows and Windows NT are registered trademarks of Microsoft Corp.

Summary

mySAP™ customers with MaxDB™ select ADINT/TSM with IBM Tivoli Storage Manager™ (TSM) as their backup/restore solution of choice for the following key benefits:

- dependable and simple Operation
 - database control (MaxDB™ built-in administration functions)
 - fully automated storage management (TSM in conjunction with tape libraries)
- Investment Protection in a dynamic mySAP™ environment
 - flexible configuration options and high performance data transfer
 - integration with ancillary administration functions
- low Total Cost of Ownership
 - efficient use of storage resources
 - no need for scripting

Background information will be provided in the following chapters.

MaxDB™ Backup/Restore with ADINT/TSM

Most of the data of a mySAP system is contained in its centralized database. Backup/restore of the mySAP database therefore deserves top attention for assuring adequate protection of vital enterprise data.

As shown in fig. 1 ADINT/TSM, unlike other backup offerings, directly connects to a standard interface of MaxDB™.

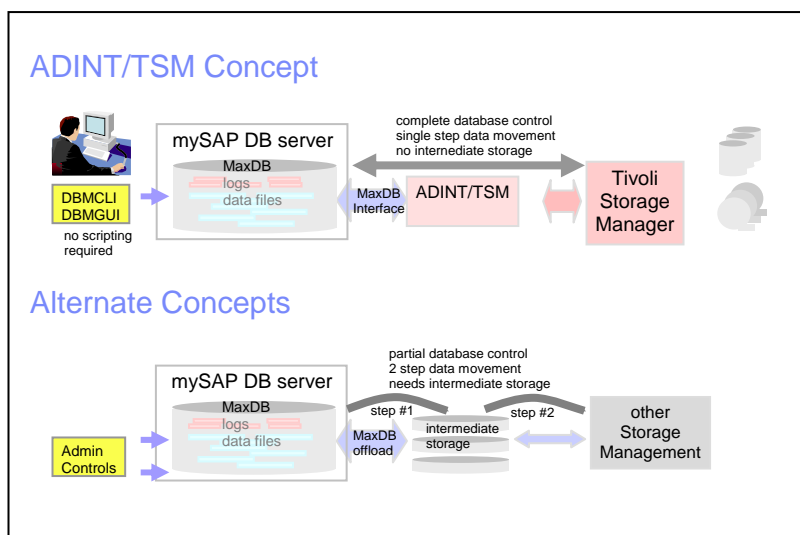

Fig. 1 Concepts for backing up MaxDB

This allows for the simplest process possible to back up MaxDB™:

- The administration functions built into MaxDB™ provide the administrator interface and optimum backup/restore functionality, and control the processes.
- ADINT/TSM transparently moves the data between MaxDB™ and TSM. No intermediate storage is necessary.

- Tivoli Storage Manager provides automated and policy-controlled functionality to most efficiently manage the storage for MaxDB™ backups, see fig.2.

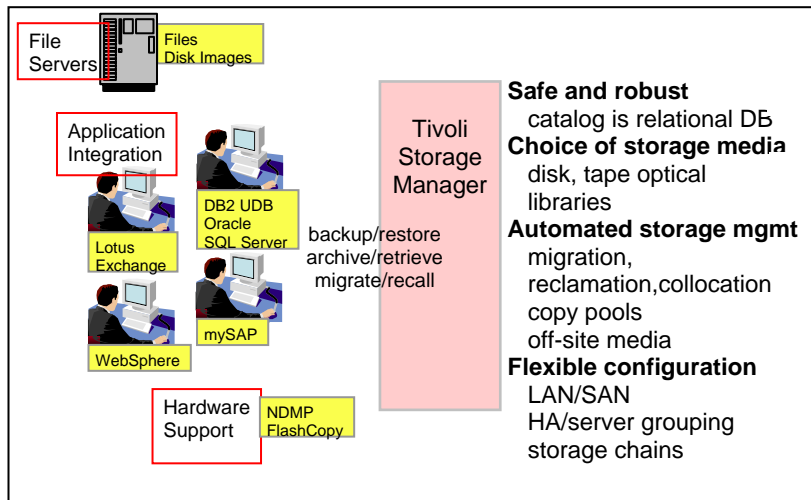

Fig. 2 Tivoli Storage Manager Functions and supported environments

TSM can not only be used for backup/restore of MaxDB™ data but also for other mySAP™ system data like executables, control files and user data to provide comprehensive data protection for mySAP™ or Netweaver™ environments. TSM provides interfaces and functions to protect other application's data as well and hence can be used as an enterprise-wide storage management tool.

ADINT/TSM Highlights

- ADINT/TSM is **fully integrated with the MaxDB™** administration function for backup and restore:
 - All MaxDB™ backup/restore/recover functions are supported, e.g.
 - database backups (full or incremental, online or offline)/restores
 - log backups and restores
- ADINT/TSM is a **proven, reliable solution**: available in the market since 1995 and chosen by a large number of SAP customers
- ADINT/TSM provides a menu of specific **functions required for production-oriented backup and restore of MaxDB™** databases, e.g.
 - Storage management (automation):
 - selectable storage media: for data backups the preferred media is tape, while log files should be backed up to disk first and later migrated to tape, see fig. 3, option A
 - automatic expiration with definable maximum number of backup generations

- **Configuration flexibility** (performance), see fig 3:
 - parallel data transfers to multiple tapes
 - single or multiple (bandwidth increase) LAN path, see fig. 3, options A or B
 - direct bulk data transfer over SAN, see fig. 3, option C

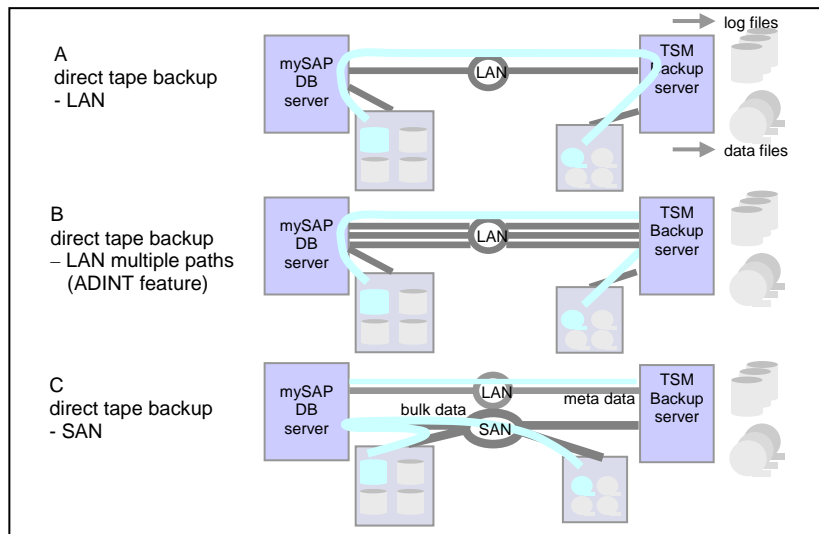

Fig. 3 Key ADINT/TSM configuration options

ADINT/TSM is supported on all major mySAP platforms, UNIX/LINUX and Windows.

Complete mySAP™ backup/restore

MaxDB™ is used in mySAP environments

- as stand-alone ERP (Enterprise Resource Planning) database
- as index database integrated into the KPro (Knowledge Management) application
- as liveCache™ integrated into the APO (Advanced Planning and Optimization) function for CRM applications

ADINT/TSM can be used to backup/restore MaxDB™ in all of the above environments.

Other system data, like control files, executables and user data can be backed up using the standard backup/archive client of TSM, see fig. 4.

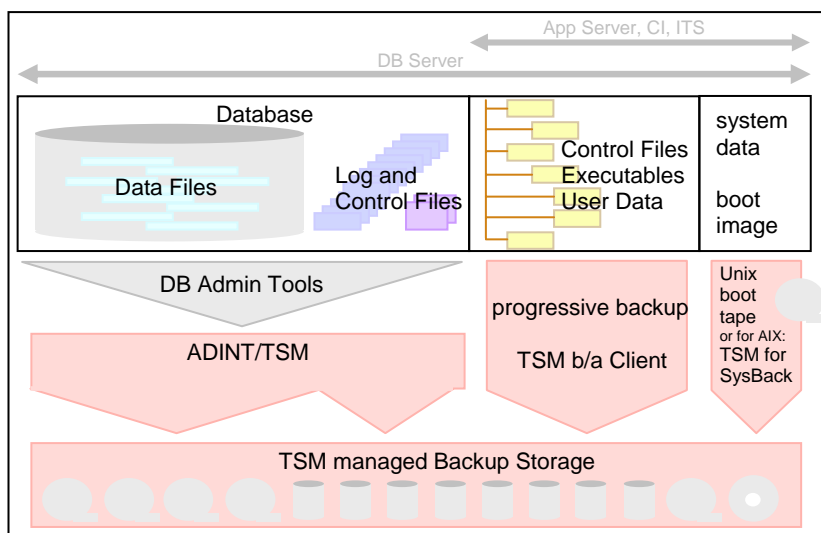

Fig. 4 Complete mySAP™ backup

These file system data usually have a much lower frequency of change and therefore need not be backed up as frequently as the database. Using the TSM progressive backup technique, which selects newly changed files only for backup, provides for a very cost-effective backup solution.

Operating system data are backed up infrequently using the appropriate operating system commands for generating a boot tape.

Ancillary Functions – Cloning and Archiving

Other administration tasks in the mySAP™ environment closely related to backup/restore are cloning/replication and data/document archiving.

Database cloning

is a process by which a new database instance is created as an identical clone to an existing one, e. g. cloning from a production to a quality assurance system for testing new releases/applications. ADINT/TSM can be used in a cloning process by restoring backup data from one MaxDB™ into another system's instance (redirected restore), see fig 5.

Positioning ADINT/TSM for mySAP™ with MaxDB™

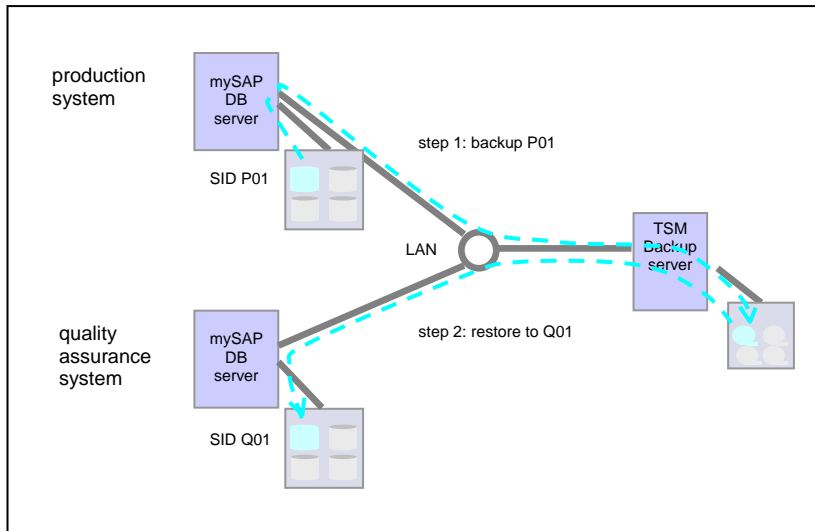

Fig. 5 MaxDB™ Cloning via redirected restore

Data archiving

is a process to extract inactive data from the productive database and store it in an external archive. Thus the mySAP™ database can be kept trimmed in size to simplify database administration and minimize response times.

SAP provides a specific interface for archiving, ArchiveLink. A special interface program, IBM CommonStore, connects Tivoli Storage manager to the ArchiveLink interface and enables TSM as an external archive for mySAP™ inactive data as well as for a variety of electronic documents.

Figure 6 shows how Tivoli Storage Manager can be deployed as a single tool to integrate mySAP system administration tasks – backup/restore and archiving.

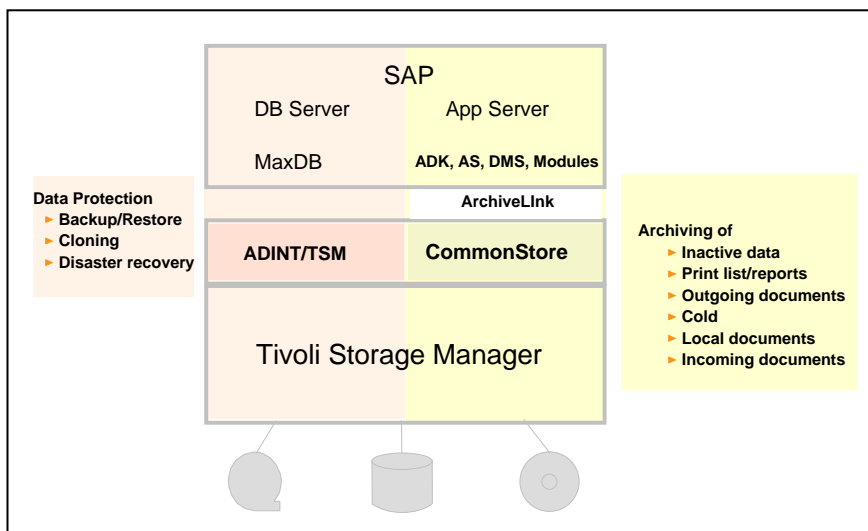

Fig. 6: mySAP Data Archiving with Tivoli Storage Manager

Overview

ADINT/TSM and *Tivoli Storage Manager* Benefits and Features

Benefits	ADINT/TSM and <i>Tivoli Storage Manager</i> Features
Production-oriented Operations	
Backup/restore/recover processes under full MaxDB control ⊕ consistency of backup data ⊕ database proven functionality	<ul style="list-style-type: none"> seamlessly integrates with MaxDB supports all functions: backup/restore/recover ,data/logs, online/offline, full/incremental
Minimum application impact ⊕ short backup/restore windows	<ul style="list-style-type: none"> connects to high-performance MaxDB interface yields high data transfer rates through multithreading supports parallelism on all levels: MaxDB pipes, tape drives, LAN paths and TSM servers
Simple operating ⊕ MaxDB administration user interface ⊕ simple/least error-prone process	<ul style="list-style-type: none"> operates transparently off MaxDB admin functions (data and logs) provides for single step processes (MaxDB directly to tape)
Automation ⊕ process monitoring ⊕ automated storage management	<ul style="list-style-type: none"> enables MaxDB to monitor processes end-to-end allows backup destination to be selected by parameter automatically expires backup generations by defined threshold <i>automatically manages backup storage (incl. tape libraries)</i>
High Availability	<ul style="list-style-type: none"> provides built-in HA functions for network and TSM server: alternate LAN paths, alternate TSM servers clustering support: Tivoli System Automation, HACMP, MSCS
Complete mySAP backup ⊕ control files, executables, user data	<ul style="list-style-type: none"> <i>backup/archive client handles file system data most efficiently through progressive backup</i>
Investment Protection	
Flexibility for changes ⊕ MaxDB configuration changes ⊕ infrastructure changes	<ul style="list-style-type: none"> automatically adapts to MaxDB configuration changes supports various network options: single/multiple LAN, SAN <i>supports all major OS platforms, disk and tape technologies</i>
Integration ⊕ ancillary SAP administration funct'ns SAP database cloning, SAP Archiving ⊕ other applications	<ul style="list-style-type: none"> supports redirected restore for MaxDB <i>together with IBM CommonStore supports data and document archiving through SAP ArchiveLink interface</i> <i>provides integration adapters to a variety of applications</i>
Total Cost of Ownership	
Efficient use of backup storage ⊕ eliminates need for temporary storage ⊕ selectable backup storage ⊕ TSM proven storage management	<ul style="list-style-type: none"> single-step process backup destination selectable in profile (cost/performance) <i>controls tape libraries and manages</i> <i>data migration to low cost storage (hierarchies, e.g. disk-tape)</i> <i>tape reclamation</i>
Short time to value ⊕ no scripting required	<ul style="list-style-type: none"> provides ready-to-use, complete end-to-end functionality
Support and Maintenance ⊕ satisfied customers (10 years in field)	<ul style="list-style-type: none"> provides central hotline support regular release updates tested and ready to use